

Copula Variation in African American Vernacular English: an investigation of the individual- and stage-level predicate hypothesis

Anne-Marie Frassica

April 2009

Honors Thesis
Linguistics Department
Swarthmore College

Abstract

This thesis investigates copula variation in African American Vernacular English (AAVE), assessing whether the variation in overt and null AAVE copular forms varies with the individual- and stage-level predicate distinction. We first justify a semantic approach to the variation and then examine the semantic and syntactic structure of individual- and stage-level copular predicates. We follow Kratzer (1989) in proposing that the predicates are distinguished by the presence of a spatiotemporal argument, but we differ in proposing that the copula plays an important function in determining the presence of such an argument. Through an investigation of predicate coercion, we argue that two copular verbs, akin to the distinct copulas, *ser* and *estar* in Spanish, determine the reading of the predicate in an AAVE copular predication. Prior work on copula absence (Becker 2004) suggests that the structure of stage-level predicates may allow for a null form of the copula to appear at the surface level of stage-level copular predications, and we attempt to extend this argument to AAVE copular predicates using data collected from a native speaker. We ultimately find that the presence of the copula is not governed by the structure of stage-level predications. Rather, examination of the distribution of the copular forms in AAVE suggests that the null copula is governed by a pragmatic constraint and is acceptable only when the proposition is contradictory to another, presupposed proposition in the discourse. Our results suggest that the standard argument that the contracted and null forms of the copula in AAVE are equivalent is insufficient in cases when both forms are permitted.

1 Introduction

One feature of African American Vernacular English (AAVE) that sets it apart from Standard English (SE) is its absent-copula main clauses. Main clauses such as *she a liar* and *that car too small* are acceptable in AAVE, as are *she's a liar* and *that car's too small*. The literature on AAVE does not consider these forms contrastive, and generally notes that the null copula is a restricted form, barred from certain environments (Labov 1969; Bender 2000). Researchers have considered the phonological and syntactic environments that might govern copular form in AAVE: the syntactic theories attempt to account for the absent copula's distribution, for instance, that it does not appear in inverted contexts or with the past tense (Bender 2000), while phonological studies liken AAVE copular distribution to SE copular distribution (Labov 1969). This paper evaluates

the potential of a semantic explanation of copula absence in AAVE, that null-copula predications are stage-level and overt-copula predications are individual-level. We use the distribution of the third-person null and contracted copular forms, as well as the behavior of predicates in aspectual *be* constructions, another form distinct to AAVE, to show that there is a semantic distinction between null and overt copular predicates. In fact, in this thesis we show the non-result that the individual- and stage-level distinction does not account for the variation in copula forms, although we do find a semantic distinction in overt- and null-copula predications in AAVE.

To give the reader some background, we first introduce the basics of verb morphology and specifically morphology on the copula in AAVE. We provide Lisa Green’s (2002) description from her text, *African American English: a linguistic introduction*. According to Green, verbs in AAVE generally do not show agreement with their subject: 1st, 2nd, and 3rd singular and plural subjects do not carry any morphology in the present tense.

	Present tense	Emphatic affirmation	Negation
1 st , 2 nd , 3 rd singular/plural	<i>Null</i>	DO	<i>don't</i>

Table 1: AAVE present tense verb morphology

Because our study will be limited to variation in the present-tense copula¹, we do not discuss the morphology of other tenses. As an exception to the rule, the copula does show some morphology, as shown in Table 2.

¹ Due to the scope of this paper, we do not consider other tenses. Variation in the past tense copula is not as pronounced – in fact, Labov (1969) and Green (2002) claim that *was* is obligatorily present. There are attested examples of past tense copula absence, but they are not given very much weight in the literature. (Bender 2000)

	Present copula	Emphatic affirmation	Negation
1 st singular	'm	AM	<i>I'm not/ain't</i>
1 st plural, 2 nd singular/plural, 3 rd singular/plural	Null	IS	<i>Ain('t)/not</i>
3 rd singular neuter	's	IS	<i>'s not/ain('t)</i>

Table 2: AAVE copula morphology

The reader should note that only the 1st person singular and 3rd singular neuter necessarily have an overt copula in the present non-emphatic. Also note that *IS* is used for emphasis in all forms except the 1st person singular. We note that it is commonly accepted that the 3rd person singular and plural is also realized as 's (Labov 1969). Although Green does not discuss contraction of the copula, the literature cites large variation in the copular forms, mostly between the contracted and null copula in the 3rd person. Green notes in her introduction to the topic that the rules she describes are not hard and fast, and that there is a large amount of variability in the language due to the social context in which it is being used. Cukor-Avila (1999) shows that rates of copula absence increase in informal environments, and Labov (1969) shows the same of group contexts, while Bender (2000) shows that copula absence has social meaning. While Green, Labov, Bender, and Cukor-Avila all show that the overt forms of the copula depend to some extent on social context, Labov's and Cukor-Avila's studies also indicate that the variation does not only depend on this variable.

Green's rules do not postulate a meaning for the use of contraction in the environments where the null copula is expected, and she describes the choice of copular form as purely optional. In fact, we find it counterintuitive that she proposes the null

copula as the standard 3rd person form despite the fact that it is prohibited in environments like ellipsis, tag questions, and inversion, and we argue later that the null copula is in fact a marked form contrastive to the contracted copula. Labov (1969) also shows that the null copula is the more restricted form. In his study, he claims that the null copula is the exception to the rule (Labov 1969). Labov argued that the AAVE copula could delete wherever the SE copula could contract, and as such, deletion was merely an extension of a process already found in SE. In his study, Labov described another patterning in copula variation in AAVE, which we consider the inspiration for this work.

In considering the distribution of the full, contracted, and null forms of the copula, Labov concluded that the copula is likely to delete, from least likely to most likely, before the following environments: noun phrases (NP), adjective phrases (AP), locative phrases (LP), verb phrases (VP), and *gonna*. Pustet (2003) showed that cross-linguistically, the copula is almost always necessary in noun predications and progressively less necessary in adjective and verb predications. Although Pustet studied variation across languages, not within them, Labov's observations align with the trend she describes, suggesting that the copula variation in AAVE is not determined solely by phonology, as Labov postulates, but rather by a constraint that could be applied cross-linguistically. Pustet suggests that a semantic feature such as time-stability correlates to the presence of the copula. Bender (2000), who considered a number of syntactic explanations of the copula variation in AAVE, suggests that, "one semantic distinction that may be having an effect is that between individual and stage level predicates" (Bender 2000; 146). We note that the permanence and stativity of a predicate are often associated with the individual- or stage-levelhood of the predicate (Kratzer 1989; Fernald

2000). Given the findings of Pustet and Labov, as well as Bender's intuition, we find Becker's (2000) work an interesting starting point for ours, as she provides an account of copula absence in Child English based on the individual- and stage-level predicate distinction. For the bulk of this thesis, we consider the distribution of copula absence in AAVE with respect to her work and the individual- and stage-level distinction.

First, we give a brief overview of variation studies, cross-linguistic copula patterning, and theories of copula absence based on the works of Labov, Pustet, Cukor-Avila, and Becker. Once we have built the basis for this investigation, we turn to our analysis of the interaction between the copula and individual- and stage-level predicates, as well as their respective structures. We conclude that there are two copulas: one whose composition with a predicate forces a stage-level reading and the other an individual-level reading. From there, we consider another particle in AAVE that has bearings on the individual- and stage-level readings of predicates, and we use its coercive capabilities in AAVE to justify our application of Becker's theory of Child English to AAVE copula absence. Finally, we discuss data gathered from an informant² that leads us to assert that the null copula is meaningful and contrastive to the contracted copula in third-person forms, but that the copular forms do not have a complementary distribution with respect to the individual- and stage-level predicate distinction. Instead, we find that the null copula presupposes another event or proposition in the discourse context, in particular, a contradictory one. We discuss how this pragmatic constraint could be incorporated briefly in terms of one of Bender's syntactic analyses of the null copula in AAVE.

² Our informant is a 23-year old African American male from Atlanta, Georgia. He speaks AAVE in his home, although he speaks Standard English as well. We recognize that, as a vernacular, AAVE can vary dependent on the age, region, and upbringing of the speaker.

Studies of Variability in the Copula

Variation studies of the AAVE copula took hold after Labov's (1969) statistical study of copula variation in AAVE. Labov's approach to copula absence in AAVE was to collect a corpus of spontaneous utterances by native speakers and analyze the rates of copula absence and contraction in all sentences. He proposed that AAVE has an underlying copula despite null forms on the surface and that copula deletion is an extension of contraction in SE. This theory assumes that AAVE and SE do not differ in the underlying form of the copula or in phonological processes. It is out of the scope of this paper to give a full discussion of the empirical fit of his theory, but Bender (2000) provides convincing evidence that the variation is not as simple as Labov makes it seem. We find that furthermore, Labov's theory fails to consider the semantic or pragmatic meaning of the variation. And while we do not subscribe to his phonological analysis of the null copula in AAVE, we find another of his results intriguing.

In his research, Labov quantified the rates of copula contraction and deletion according to the syntactic category (NP, PP, AP, VP, *gonna*) of the predicate and of the subject (NP, pronoun). Statistical analysis showed that the syntactic category of the predicate correlated with copula absence, as did that of the subject. He posited variable rules to account for the data, assigning a different probability for observing the null copula before each syntactic environment. We find this result, rather than his phonological theory, the most intriguing, and we suggest that this patterning reflects a different motivation for copula absence.

We are intrigued by the finding that the syntactic category of the predicate is significant in the distribution of the null copula, and we will focus on this finding.

Labov's data have been reanalyzed using different methods of counting overt and null forms of the copula, and other researchers have undertaken their own variation studies on the AAVE copula, Gullah, Jamaican Creole, and African Nova Scotian English copulas (Baugh 1980; Holm 1984; Rickford 1996; Weldon 1996; Winford 1992; others). Holm, Baugh, Rickford and Blake (1990), and Rickford (1998) found that in their studies, the data showed different trends depending on the method used to classify and count the copula utterances. That is, the decision of what constituted a copula-less predication could make the frequency of deletion before an AP appear greater than that of a PP³. Since then, studies of English-based creoles have shown inconsistent results on the question of null copula frequency before PPs and APs and even on the frequency of absence before PPs and NPs.

Nevertheless, studies confirm Labov's basic finding that the copula varies with the syntactic category of the predicate although they do not reach a consensus on the ordering of copula frequency. Bender (2000), in a study of the social importance of copula variability, finds that although the overall rate of copula deletion falls in certain social contexts, the patterning with VPs, PPs, APs, and NPs remains roughly the same. Cukor-Avila (1999) also studies variation in the copula, confirming Labov's observation on the syntactic categories of the predicates and calling for further analysis of them. We see shortly that a cross-linguistic study of copular predications shows that the presence of

³ The method Rickford (1999) calls for is Straight Deletion. Under this method, the frequency of deletion is defined as $D/F+C+D$ (where D is the number of sentences with a deleted copula, F with a full copula, and C with a contracted copula). The same computation can be done for contraction: $C/F+C+D$. Labov, in contrast computes the frequency of deletion as $D/C+D$ (because he considers deletion just a continuation of contraction, summing C and F would be redundant) and contraction as $C+D/F+C+D$ (because deletion necessarily first involved contraction).

the copula varies with the syntactic category of the predicate, and further, that several features of the predicate, especially time-stability, may play a role in this variation.

The pattern proposed by Labov and confirmed by Bender (2000) and Cukor-Avila (1999) evidences an underlying semantic or syntactic, rather than phonological, explanation of the copula variation in AAVE, and in this thesis, we consider an alternate explanation of copula variation in AAVE and we move away from the statistical approach. Bender (2000) notes that variation studies are sensitive to the group of speakers polled, the environment of polling, and the counting method used. Not only do variation studies pivot on the reliability of the statistical analysis and data collection methods, but they also hide the structure accounting for the absence or presence of the copula itself. While these researchers do provide some explanation for the variation, they do not go beyond a descriptive account into the motivation that actually underlies the phenomenon. If Labov's phonological theory does stand up to all empirical evidence, what does that say about the nature of contraction and deletion? Why does the null copula occur more frequently in some environments than others? And if his theory is not satisfactory, what do his initial observations suggest?

We propose that the features of the property predicated of a subject in these constructions may be a very important factor in copula presence. More investigation of these environments and their correlation with the presence of the copula is necessary. Cukor-Avila (1999) and Bender (2000) note that no study thus far has analyzed the subcategories of predicates that occur after the copula, and we next present Pustet's cross-linguistic study of the factors governing copula absence and Cukor-Avila's consideration of the correlation between stativity and copula presence. Then, we consider

the structure of the copula as well as individual- and stage-level predicates and move to analyzing AAVE copular forms with an eye to the classification of the predicate.

Cross-linguistic Evidence for a Semantic Distinction

Pustet (2003) offers a cross-linguistic study of copula function and distribution in 154 languages in which she identifies four characteristics of predicates that correlate with copula presence. Pustet outlines four parameters of predicates that she finds correlate with copula presence: DYNAMICITY, TRANSIENCE, TRANSITIVITY, and DEPENDENCY. We do not discuss these parameters separately but rather consider them combined under the term *time-stability*, which Pustet stresses more than we do as a factor determining copula presence in a predicate, although it may certainly be a variable correlated with the individual- and stage-level predicate distinction. In her analysis, she finds that nouns are the most time-stable, then adjectives, and finally verbs. Her findings show that the copula patterns, to some extent, on this time stability, leading her to present a scalar ordering of these predicates in respect to copula presence: VP > AP > NP. That is to say, languages that require the copula before a VP will require it before APs and NPs, those that do not require it before VPs, but do before APs, also will require it before NPs, and so on. This ordering suggests that the more time-stable a predicate the more necessary an overt form of the copula.

Patterns of copula distribution

	NOMINALS	ADJECTIVALS	VERBALS
Tagalog	-	-	-
Lakota	+/-	-	-
Burmese	+	-	-
Japanese	+	+/-	-
German	+	+	-
Basque	+	+	+/-
Bambara	+	+	+

(+ = copula used in predicate position; - = copula not used in predicate position)

Figure 1

(Pustet 2003; 64)

In Figure 1, we see this ordering in a sample of languages from her study. Pustet notes that one language requires the copula with APs but not with NPs, but for the vast majority of languages, the other 153 she studied, the ordering is as she predicted. This ordering looks very similar to the ordering Labov identified in the data he studied, that copula presence is least necessary before VPs, PPs, then APs, and finally NPs. Given this similarity, we consider the possibility of a semantic constraint to explain the copula absence in AAVE, rather than a language-specific, phonological explanation.

Pustet attributes this scalar ordering of copula presence to the time-stability of the different syntactic categories. Maienborn (to appear), in a review of Pustet's theory, suggests that some of the factors of time-stability, such as transience, may not actually influence the form of the copula. She argues that although most researchers claim the distinction between the Spanish copulas *ser* and *estar* lies in the transience of the properties, the distinction actually lies in discourse structure, *estar* being a marked form. We follow Milsark (1997) and Diesing (1992) among others, who propose that the distinction is neither time-stability nor discourse structure but rather the type of property they select: individual- or stage-level. Many researchers in semantics (Kratzer, Becker,

Green) have conflated transience with individual- and stage-levelhood, but we follow Fernald (2000) in arguing that they are not the same. Fernald reasons that just because a property is predicated of a subject for a finite amount of time does not make it stage-level (Fernald 2000; 70). We clarify the concept of individual- and stage-level predicates, and its distinction from permanence and transience shortly. Because transience is so often conflated with a stage-level reading, and because there may be some true correlation, at least in the canonical use of certain properties, we do not find Pustet's claim that time-stability determines copula presence entirely false, but that it may attribute the distinction to a false parameter.

Although we find Pustet's descriptions of cross-linguistic copula patterning intriguing, we do not agree with all of the assumptions made in her study, nor do we have experience with the languages she examines, and we note that distinguishing copular entities in a language is not trivial. We speak to just one of Pustet's assumptions here, as it relates to the work we pursue for the remainder of this work. Pustet claims that the copula has no semantic meaning or function, but rather that the characteristics she describes are inherent of the properties predicated of the subjects, despite the prevalence of minimal pairs with and without the copula. Maienborn's review of Pustet (2003) suggests that on the contrary, it would be more elegant to suggest that the copula does contribute semantic meaning than to suggest that there some properties in the lexicon have more than one meaning. We find further support for this theory later in our analysis, in which we argue that AAVE, along with Spanish and Standard English, has two copular verbs that determine the reading of the predicate. Despite our disagreements with some of Pustet's assumptions and conclusions, we use her cross-linguistic findings of the scalar

ordering of NP, AP, and VP to strengthen Labov's findings in AAVE – that the copula is most necessary before NPs, then APs, and finally PPs and VPs – and to support a semantic investigation of AAVE copular absence. Pustet's time-stability hypothesis provides support for an investigation of the individual- and stage-level distinction of copular predicates. Cukor-Avila's (1999) study, which we discuss next, is the closest approximation to this type of investigation in the literature.

Cukor-Avila and the Stativity of AAVE Adjectival Phrases

Cukor-Avila (1999) discusses her dissatisfaction with variation studies of copula absence in AAVE. She points out that copious statistical studies have attempted to capture whether APs or PPs are more likely to appear without a copula, but that no prior studies have considered the sub-categories that may exist within these syntactic categories. And we are concerned with just this – what it is about the syntactic category of a property that correlates with copula absence. In her study, Cukor-Avila splits adjectives based on their stativity and finds that less-stative adjectives are more likely to appear with copula absence than stative ones are. We note that stativity is also a feature correlated with the individual- and stage-level distinction, and not so different from some of the parameters Pustet suggested.

Cukor-Avila studies the distinction in copula presence before stative, non-stative, and participial adjectives. She gives examples of stative adjectives, such as *tall* and *rich*, and non-stative adjectives such as *jealous* and *noisy*. Notice that non-stative APs can be used in the progressive, e.g. *He is being noisy*, whereas stative APs cannot, e.g. **He is being tall*. Participial adjectives stem directly from verbs, for instance *broken* or *gone*.

Working from hypotheses made by Lakoff (1966, 1970) and Givón (1970, 1984), Cukor-Avila postulates that ‘noun-based’ adjectives will be stative, and behave like nouns in relation to copula absence, and that ‘verb-based’ adjectives will be non-stative, and behave like verbs in relation to the copula.

To test her hypothesis, Cukor-Avila studied rural speakers of AAVE born between 1895 and 1995 and found that their rates of copula absence followed the same pattern described by Labov. She then took the analysis a step further and analyzed the three types of adjectives separately. She found that stative adjectives pattern more with NPs, exhibiting lower rates of copula absence, and that non-stative and participial adjectives pattern like VPs, exhibiting higher rates of copula absence.

VARBRUL Factor Weight Analysis for Copula Absence Preceding Stative, Nonstative, and Participial Adjectives for Two Generations of Springville Residents

	Pre-World War II ^a	Post-World War II ^b
Stative	.46	.43
Nonstative	.36	.84
Participial	.71	.81

Figure 2

(Cukor-Avila 1999; 348)

The chart above shows Cukor-Avila’s results for the two groups she studied. The tendency towards the null copula is quantified using the variable rule (VARBURL⁴) method, a higher number indicating a higher propensity for appearing with copula absence. Her results suggest strongly that stativity is related to copula absence in AAVE, and, on a side note, that the patterning in the null copula has changed in recent generations.

⁴ VARBRUL was developed by Cedergren and Sanko (1974), based on the work of Labov (1969), to provide a consistent method of determining the frequency of copula absence using a step-wise multiple regression. The values are bounded by 0 and 1; lower the value, the less likely the feature being regressed.

Although we find Cukor-Avila's results encouraging, we note that her method of counting and categorizing predicates may be too simple because it does not take into account coercive environments, in which a generally stative predicate could be used in a non-stative environment, and vice versa. Still, we find in her results further evidence that the individual- and stage-level distinction may be important to our understanding of how the copula varies in AAVE. Neither Cukor-Avila nor Pustet discuss their results in terms of individual and stage-level predicates, but both stativity and time-stability are related to that distinction. In regards to stativity, individual-level predicates are all stative, and stage-level predicates can be either stative or non-stative. Given Cukor-Avila's work, we propose that because individual-level predicates are stative, they will pattern like stative APs and require the overt copula more often, and that because stage-level predicates can be non-stative, they will not require the copula as often. We see later in the work of Becker (2004) that there is evidence for the argument that all NPs are individual-level, all PPs that appear with the copula are stage-level, and APs are mixed. Prepositional phrases can be stative or non-stative, but the non-stative ones will only follow non-stative verbs, so we can only expect stative PPs to be directly chosen by the copula, and they may be individual- or stage-level given the characteristics we have discussed thus far. We will not continue to discuss VP patterning with the verb *be* because this is not generally considered a copula but rather an auxiliary. Instead, we focus our efforts on the copula as it selects NPs, APs, and PPs. The individual- and stage-level predicate distinction then may tie in the concepts of stativity, transience, as well as syntactic category in respect to copula absence.

level distinction to predict copula absence in AAVE. In the next section, we discuss Becker's theory of copula absence in Child English (CE), which proposes that the copula is allowed to delete in stage-level predicates of CE. We modify Becker's account of the copula and then use evidence from the patterning of the aspectual *be* in AAVE, which we show distinguishes individual- and stage-level predicates, to justify the application of her theory of CE to AAVE. We show that although the copula is responsible for the individual- and stage-level reading of copular predicates, its null form in AAVE is not governed by the predicate distinction. Instead, we find that there is a different distinction between overt copula and null copula clauses: namely, null copula clauses presuppose a contrary proposition in the discourse.

Becker's Theory of Copula Absence

Becker (2004) studies copula absence in Child English (CE), and her theory provides a foundation from which we can develop and test a similar theory of copula absence in AAVE. We provide an overview of Becker's findings on the distribution of NPs, APs, and PPs in individual- and stage-level predicates here to motivate further our investigation and then briefly introduce her theory of the structure of copular predicates, which we discuss more thoroughly in the next section.

Becker's analysis of English predicate patterning shows interesting similarities with Labov's findings regarding the frequency of copula absence before the different syntactic categories. Becker constructed the chart below to categorize some common properties in terms of syntactic category and ordered by permanence (most permanent at the top).

NPs	APs	PPs
species/kind (<i>a human</i>)	species/kind (<i>human</i>)	necessary locations (<i>in the known universe</i>)
gender/type (<i>a woman</i>)	gender/type (<i>female</i>)	locations of events (<i>the party is in the garden</i>)
nationality (<i>an American</i>)	nationality (<i>American</i>)	locations of immobile things (cities/islands)
professions (<i>a doctor</i>)	shape/color/size (<i>round, red, small</i>)	locations of mobile things (people/objects)
stage of life (<i>a young/old woman</i>)	stage of life (<i>young/old</i>)	
<i>neighbor</i>	energy level/emotions	
<i>fugitive/contestant</i>	(<i>tired, happy</i>)	

Figure 4

(Becker 2004; 69)

Becker separates this chart based on each property's use in English; above the line are individual-level properties and below the line, stage-level ones. Note that NPs are canonically individual-level, APs are largely individual-level, and PPs are stage-level. Becker argues that NPs never appear with a null copula in CE, and that neither do the majority of APs, whereas PPs do not appear with an overt copula. This matches roughly Labov's description of the probability of copula absence with each of these environments in AAVE: NPs should not appear without the copula, APs should show some patterning without the copula, and PPs should show the highest frequency with the null copula. Becker's account explains the distribution of the null copula in CE and provides a foundation for our work on the null copula in AAVE.

Becker's observation that children only omit the copula before stage-level predicates in CE leads her to explore the structure of individual- and stage-level predicates and to postulate a semantic and syntactic difference between them that could account for the differing copular behavior. In particular, she assumes, following Krazter (1989) that stage-level predicates project a spatiotemporal argument, and she furthers

Kratzer's hypothesis by positing two extra functional heads in the structure of these predicates. These functional heads can be bound by the Temporal Operator⁵ in her theory, and because she argues that the copula carries only tense information, it will not surface in the case that one of the other functional heads is bound.

Becker gives a brief discussion of the possible application of this theory to AAVE but decides against its feasibility because AAVE allows copula absence before NPs. She predicts that NPs cannot project spatiotemporal arguments, that is, that they cannot be stage-level. If the NP problem is reconciled, Becker's theory could account for the increasing likeliness of copula absence before NPs, APs, and PPs in AAVE. Our efforts in the remainder of this study are largely focused on determining the applicability and fit of this theory of CE to AAVE.

First, we more formally introduce the copula and individual- and stage-level predicates. Whereas Becker argues that stage-level properties themselves project the extra functional heads and the copula has no function, we argue that those structures are actually contributed by a copular verb, in SE and in AAVE, *be*. Specifically, we argue for two forms of the copula, one that has selects extra functional heads, through which it forces its predicates to have a semantic event argument, and one that does not. This differs from Becker's interpretation of *be* as an auxiliary with no role in predication. After establishing our proposed structure of copular predicates, we consider evidence of NPs occurring as stage-level predicates in AAVE, which Becker predicted could not happen.

⁵ We forward the reader to Becker (2004) for a comprehensive discussion of this theory.

The copula and individual- and stage-level predicates

Carlson proposes that individual-level properties are predicated of individuals (all objects, animate or not, e.g. *a robin*, and kinds, e.g. *birds*) as their arguments and stage-level properties are predicated of stages of individuals. Carlson (1977) considers a stage to be “roughly, a spatially and temporally bounded manifestation of something,” and correspondingly, “an individual, then is (at least) that whatever-it-is that ties a series of stages together to make them stages of the same thing.” (Carlson 1977: 115)

- (1) Mary is a doctor.
- (2) Mary is at the hospital

Then, *a doctor* is predicated of the individual Mary, whereas *at the hospital* is predicated of a stage of Mary. (1) holds no matter what Mary is doing when the speaker makes the utterance (starting from the time Mary finished medical school) or where Mary is. On the other hand, (2) depends very much on Mary’s location in time and space; this statement is not a claim about Mary as a whole, but rather about one instance of Mary.

Carlson shows also that these predicates act differently when it comes to bare plurals, existential statements, and perception verb environments. He notices that bare plurals behave differently when the predicate is individual-level as opposed to stage-level. The predication of individual-level properties produces generic readings only, but predication of stage-level properties produces existential or generic readings.

- (3) Doctors are smart.
- (4) Doctors are on the third floor.

(3) is a generic statement about doctors, whereas (4) could be an existential statement about stages of a set of doctors or a generic claim about where one might normally find

doctors. As an extension of this behavior, Carlson also shows that only stage-level properties can appear in the coda of an existential.

- (5) There are doctors on the third floor.
- (6) *There are doctors smart.

Furthermore, only stage-level properties can be selected as perception verb complements. Perception verbs include verbs like *see*, *hear*, and *observe*. Of course, there are also other restrictions on what can be seen and heard and observed (they must be outwardly visible/audible properties, or properties that describe a behavior), but the test holds nonetheless.

- (7) *He saw her tall.
- (8) *He saw her a doctor.
- (9) He saw her in the testing room.
- (10) He saw her available.

Notice that the properties allowable in the coda, those in (9) and (10), are stage-level. They do not speak to the nature of an individual but rather to that individual at a specific time, place, or event - to a stage of the individual. These properties are also differentiated by their behavior in other environments, such as with adverbs of quantification, or spatiotemporal modification, as detailed by Kratzer (1989), but we do not discuss this at length here.

Carlson (1977) proposed two homophonous entries for *be*, one that acts as a realization function (as he termed it) between the property and the stages of the individual (be_s), and the other he suggested had no real semantic function (be_i). In his theory, the forms of a copular construction are as follows.

- (11) subject be_s complement = $\exists s[R(s,y) \ \& \ c(y)]$
- (12) subject be_i complement = $c(s)$

In (11), be_s serves as the realization function, R , which maps the stages of an individual, y , to that individual, s , such that we have realized the certain stages of an individual that also have the property denoted by the complement, c . In (12), there is no quantification, and the copula serves no function; the complement is a one-place function that takes the subject, an individual or kind, as its argument and returns a truth-value. (13) and (14) provide examples of the two different copulas in English and formal logic.

(13) John is a barber.

barber(John)

(14) John is at the door.

$\exists s[R(s,j) \ \& \ \text{at-the-door}(j)]$

In contrast, Kratzer (1989) argues that the predicates are differentiated by the information necessary to interpret them, not by the copula that forms them. In Kratzer's analysis, stage-level predicates (like *at the hospital*) have an extra argument in their semantic type, allowing them to be linked to a time and place, essentially to a stage of an individual. Kratzer adopts and extends the idea of the spatiotemporal argument described in Davidson's (1967) theory of event arguments. Davidson argued that non-stative verbs require extra information to be understood, and that this information could come in the form of an unspecified number of modifiers, such as time or place modifiers. He suggested that instead of accommodating these extra modifiers one by one in the structure, non-stative verbs have an event argument to hold them. Kratzer refers to this argument as a spatiotemporal argument. Indeed, it is intuitively satisfying that non-stative (or, incidentally, eventive) verbs be linked to an event that occurs at a certain time and place. Kratzer hypothesizes that stage-level predicates of all syntactic categories, like non-stative verbs, also have an event argument. As we saw in (2), *at the hospital* only

held of Mary at a certain time and place, whereas *a doctor*, the property in (1), was not similarly restricted.

Kratzer formalizes this notion of a spatio-temporal argument in the semantic and syntactic structure of the predicates. In her analysis, stage-level predicates are linked to an event that posits a location variable (*l*, following Barwise and Perry 1983) in the semantic structure of the predicate. Whereas individual-level predicates are $\langle e, t \rangle$, stage-level predicates require another argument, *l*. We will assume their structure to be $\langle e, \langle l, t \rangle \rangle$, although Kratzer never details this, such that the predicate first requires an individual, *e*, and then a sub-specification, *l*, of the stages of that individual in order to return the truth value of the proposition. Kratzer's spatiotemporal argument is then realized in the syntax of these predicates as an Event argument, which is projected in the specifier of IP.

Stage-level:

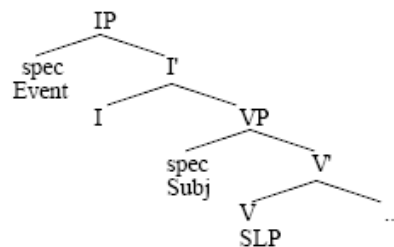

Figure 5

Individual-level:

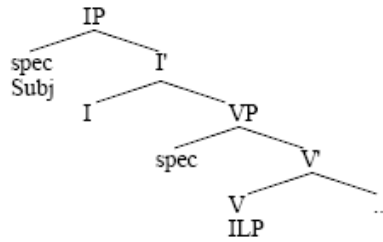

Figure 6

(Becker 2004; 30)

Kratzer argues that quantifiers bind location variables; so individual-level predicates, which are not linked to an event, cannot appear in *when*-clauses because vacuous quantification would occur, and similarly cannot be spatiotemporally modified, because there is no argument (*I*) to accept the modification.

These structures suffer from a few flaws. Becker (2004) points out that this structure strays from the Verb Internal Subject Hypothesis because the thematic subjects are not projected by the predicates. Furthermore, Fernald (2000) points out that her treatment of theta-roles is non-standard because it does not serve to fulfill the Projection Principle or Theta Criterion. Kratzer's argument that events are the thematic subjects of stage-level predicates follows Carlson's original notion (if we loosely equate stages of individuals with events) that some predicates compose with individuals and others with stages, but it does not sit well in the syntax as she proposes it. And as we see shortly, her account that the syntactic differences come from event projection by the property does not stand up well to cross-linguistic data. Before presenting that data, we consider Becker's revision of Kratzer's syntactic analysis of the event argument and submit it as well to cross-linguistic data at the same time.

Becker also proposes that stage-level predicates require a spatiotemporal argument, and individual-level predicates do not. The copula in this theory is an auxiliary.

Individual-level:

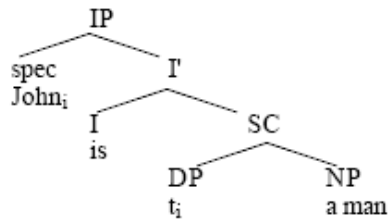

Figure 7

(Becker 2004; 112)

Stage-level predicates are more complex. The figure below shows a stage-level predicate selected by *saw*. This predicate, *in the garden*, has two layers of structure above it, an Ev(ent)P(redicate) and an Asp(ect)P(redicate). The EvP is a syntactic projection of the event argument in the semantic structure of the predicate. Becker proposes that the predicates project AspP⁶ between the small clause that contains them and the VP, and that the EvP projected by stage-level predicates is selected by AspP. Then, I' selects AspP (for stage-level predicates) or a small clause (for individual-level predicates), and *is* is the result of the binding of Infl.

Stage-level:

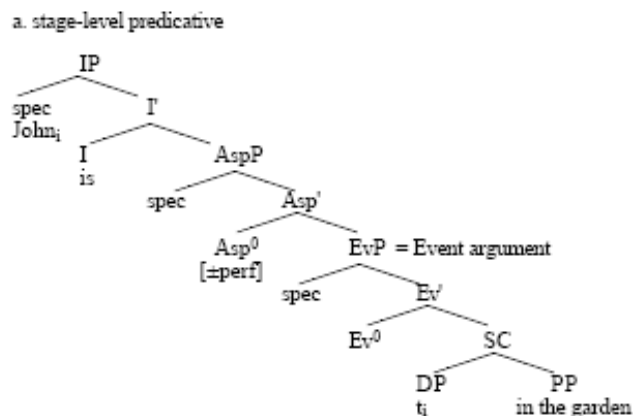

Figure 8

(Becker 2004; 112)

⁶ McClure (1993) among others, suggest that this AspP structure is necessary for the invertibility of *be* constructions (Heycock (1995)). We will not consider further evidence for the AspP structure but direct the reader to Becker (2004) for more detail.

By confining AspP projection to stage-level predicates in her theory, Becker disallows the existential reading of individual-level predicates. Becker follows Heycock in proposing that EvP carries an existential quantifier that binds all variables in its complement existentially, and as such, it is not clear how Becker would allow the generic reading of stage-level predicates. We suggest that the generic reading of a sentence like *nurses are on the third floor* does not contain a stage-level predicate because with a generic reading, *on the third floor* is a property of nurses in a certain hospital; it holds of the nurses regardless of their location at a given time. Then, the predicate could not be dominated by EvP, i.e. bound existentially.

Becker's motivation for the structure of stage-level and individual-level predicates is that in her data from Child English, *be* is only ever absent before stage-level predicates. She argues that the presence of AspP allows for this absence, and as such, linking EvP to AspP ensures that *be* is only absent when an event argument is projected.

We agree with Becker's theory that AspP (and therefore the event argument) is only present when there is a stage-level reading associated with a predicate, but we postulate that the verb that composes with the predicate is responsible for this structure. If we consider minimal pairs such as (15) and (16), we see that under Kratzer and Becker, the distinction between the two sentences does not come just from the predicate *cold* unless we postulate polysemous entries for the property and rely on context to distinguish them. Alternatively, *cold* has only one meaning and a secondary meaning is coerced in one of these pairings.

- (15) Mary is cold.
(Mary is impersonal.)
- (16) Mary is cold.
(Mary is not warm enough.)

Spanish data shows that context is not necessary to understand the different meanings of the copular sentences below. In (17) and (18) we have the same subject and complement, but the copula used to join them is different, and not optionally so.

- (17) Pepe es malo.
Joe ser-3sg bad
(Joe is (morally) bad or naughty.)
- (18) Pepe está malo.
Joe estar-3sg bad
(Pepe is sick, or ill.)

Taken out of context, (17) and (18) are perfectly distinguishable. To account for this data, which requires no context, Kratzer and Becker would have to argue that *malo* is polysemous – that in (18) *malo* has EvP and AspP structure, and in (17) it does not.

While many words are in fact polysemous, we can construct sentence pairs like (17) and (18) with different predicates, some of which produce awkward yet acceptable readings. This awkwardness implies that the verb may have affected the change in the meaning of the predicate, coercing it in a way that could be more difficult for some predicates than others. The fact that predicates can feel coerced suggests that there are not originally two homophonous predicates with a difference in underlying specification, but rather that there is some productive process here. Whereas context might distinguish the meaning of two truly polysemous words, it seems that the copula in Spanish forces the reader to understand the property in a different way. Fernald (2000) discusses a number of English environments that also cause coercion. We argue that composition with the verb, in this case the copula, determines the individual- or stage-level reading of the predicate. This evidence leads us to consider two distinct copulas that are structurally

different, and we discuss their structure and the process by which predicates can change meaning below.

We argue that there are two entries for the copula, both in English and in Spanish, although in English they happen to be homophonous. Our theory can account for Becker's observations on Child English, the minimal pairs in Spanish and English, and the restrictions on the syntactic environments in which a stage- or individual-level reading is allowable. This theory of two copular verbs suggests a structure such as the following, which resembles very closely Becker's structures of ILP and SLP copular phrases, except that we consider the copula a main verb in our structure, and that the AspP and EvP structure are attributed to it rather than to the property chosen to be predicated. The structure shown below is the copula that forces a stage-level reading. The complement of the *be_s* verb phrase is AspP, which in turn selects an EvP as its complement.

Stage-level:

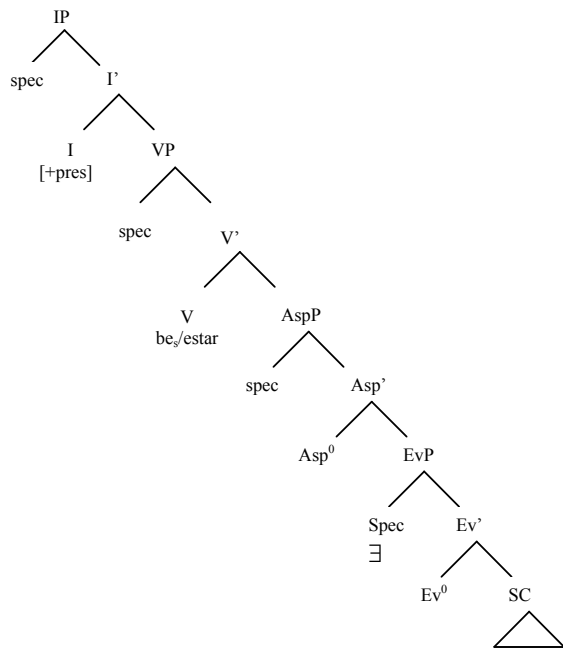

Figure 9

The small clause (sc) selected as the complement of the EvP contains the property to be predicated, such as *cold* or *malo*. Kratzer did not flesh out her theory that stage-level predicates require an extra argument, and we follow Fernald (2000) in proposing that the type of the predicate is either $\langle l, \langle e, t \rangle \rangle$ or $\langle e, \langle l, t \rangle \rangle$. While Fernald discusses this specification and its implications, we will not consider it further. In either case, the structure requires a spatiotemporal (location) argument in the structure, forcing the predication of the subject to be linked to an event. If the property described by the predicate cannot be linked to a certain point in time and space, it is rejected. Consider the composition of the following properties with *estar*.

- (19) *está* *a la puerta*
 estar-3sg *at the door*
 (it is at the door)
- (20) *está* *bonita*

	estar-3sg	pretty
	(she is pretty, at the moment)	
(21)	*está	azul
	estar-3sg	blue
	(it is blue)	

We argue that these properties are not necessarily pre-defined as individual- or stage-level, but we do acknowledge that they have a canonical use. If the property is canonically stage-level, as is *a la puerta* (at the door), then no extra work needs to be done. If the property is canonically individual-level, as *bonita* is, then it will attempt to take the spatiotemporal argument. This may require the recipient to understand the property in a slightly different way. In (20), *está bonita* must be understood to mean that the girl is looking very pretty at the time of utterance, but that she is not generally so pretty. If an individual-level predicate such as *azul* composes with *estar*, the sentence is rejected because in Spanish colors cannot take a spatio-temporal argument.

Notice that we do not claim that there is a hard line between properties that are naturally linked to an event, and thus have a spatiotemporal argument, and those that are not. In our analysis, the properties themselves do not automatically have EvP and AspP structure; rather, this structure is contributed by the copula. So although we may most often find *on the third floor* in a stage-level predicate (meaning we generally associate it with a spatiotemporal argument), it can be used without such an argument to give a generic, individual-level reading, but in this case it would compose with *be_i*, for instance in the sentence *accountants are on the third floor*. In Spanish, *bonita* is most commonly used to speak to an inherent characteristic, but it can be used in contexts to mean something more accidental. The ability of a property to be linked to an event seems to be largely up to the discretion of the language and the participants in the conversation.

Recall that our structure needs to account for the prohibition of ILPs as perception verb complements and existential complements. Due to the scope of this paper, we will not give a full argument here, but we follow Becker in claiming that perception verbs select AspP structure. Again, in our analysis, we reformulate this to state that perception verbs contain AspP and EvP structure that forces any property they select to be linked to an event, taking on stage-level meaning. Our structure also allows the acceptance of only stage-level predicates in the codas of existential *there* sentences. If we consider *there* to be an existential quantifier, we would find that individual-level predicates do not provide a variable to be bound, whereas stage-level predicates contain the spatiotemporal argument to act as the variable. Furthermore, we follow Kratzer in proposing that only stage-level predicates can be spatiotemporally modified because it is the event argument being modified, and that only stage-level predicates can be bound by an adverb of quantification because individual-level predicates do not provide a variable for binding.

We have shown the structure for the copula that produces stage-level readings, and now we consider the copula that produces individual-level readings, *be_i*. This structure does not impose a spatiotemporal argument on the property selected; in fact, it prohibits them. The predicate in this structure is of type $\langle e, t \rangle$, such that there is no way to accommodate a spatiotemporal argument.

Individual-level:

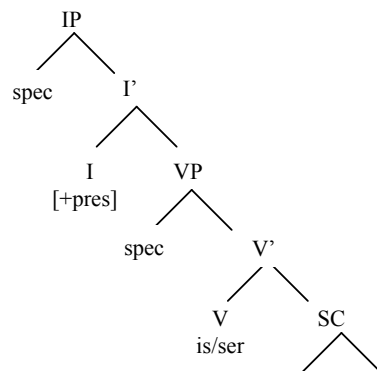

Figure 10

In this structure, the verb selects a small clause directly; in this case, the verb phrase does not contain AspP or EvP structure, and therefore does not contain an existential quantifier either. This allows the subject of the predicate to be interpreted generically as Carlson observed. So, if a canonically stage-level property (one that we think of as often having a spatiotemporal argument) were in the small clause in this structure, it would either be coerced into losing its spatiotemporal argument or be rejected because it would not compose correctly.

- (22) *es azul*
ser-3sg blue
(it is blue)
- (23) *es frio*
ser-3sg cold
(it is cold)
- (24) **es a la puerta*
ser-3sg at the door
(it is at the door)

If the property canonically has no spatiotemporal argument, like *azul*, it is accepted, the subject filling the one argument necessary for the predicate. If it does have one and can be coerced, like *frio* (cold) might, it is coerced to have individual-level meaning and take on the meaning of *impersonal*. Finally, as in (24), if it cannot lose its spatiotemporal argument, it is rejected. Again, consider the case of existential codas. There is no spatiotemporal argument introduced in the structure, and *there* has an implicit existential quantifier; vacuous quantification is not allowed, so this composition fails. Again, there is

no spatiotemporal argument to accept modification or to be bound by an adverb of quantification.

Our theory holds that predicates may have a canonical interpretation, stage- or individual-level, but that ultimately their acceptability is determined by the copula that selects them. If they are the complements of be_s , they must be linked to an event or the composition will fail. The existential quantifier introduced by EvP accounts for the existential readings in stage-level copular constructions, and the location argument allows for its acceptability in *there* existentials, perception verb complements, quantification, and spatiotemporal modification. The individual-level form of the copula does not have AspP or EvP structure – it disallows spatio-temporal arguments because composition would fail if a spatiotemporal argument were present. There is no existential quantifier in the structure because there is no EvP, and as such bare nouns composed with be_i result in a generic reading. Individual-level predicates cannot appear in the coda of an existential because they do not posit a variable that can be existentially quantified over or be spatiotemporally modified.

We have examined copular predicates and their classification as individual- or stage-level in an effort to understand their structure so that we might apply an analysis like Becker's to AAVE null-copula predicates. It turns out that the coercive power of AspP and EvP will be very relevant to our approach, and that identifying coercion is almost as important. Thus far, we have established that the copula can coerce properties to have readings one way or the other. We recognize that in English, these two verbs are homophonous, but that in Spanish, for instance, they are distinct. Our theory of copular predicates has implications for Becker's suggestion that her theory of copula absence

cannot be applied to AAVE. Becker argued that because NPs were ILP, and thus did not have AspP structure, no null-copula predicates could contain noun phrases, and that therefore, her hypothesis could not explain the forms in AAVE. Given the structure we propose, this is no longer the case. In theory, the AspP/EvP structure of *be_s* can coerce any predicate. Perhaps it is the case that CE does not allow NPs to adopt spatiotemporal arguments. In the following section, we argue that AAVE does in fact allow just this sort of coercion.

Aspectual Be and Individual- and Stage-level Predicates

In this section we discuss how we can use the aspectual *be* to show that NPs can occur with stage-level reading, i.e. in the complement of EvP, in AAVE. We find that the aspectual *be* forces its complement to be stage-level, much like *be_s* does. Green (2000) discusses AAVE's aspectual *be*, and we present her interpretation of the aspectual *be* here. The following examples show the contrastive meanings of the aspectual *be* and the copula when composed with *lyin'*.

(25) She('s) lyin'.
(She is lying right now⁷.)

(26) She be lyin'.
(She always lies (in this kind of situation).)

Notice that the difference between (25) and (26) is substantial. (25) means that at the time of utterance, the subject was lying. (26) corresponds loosely to the generic reading given by the simple present in SE, but Green points out that there is a substantial difference: (26) differs from the habitual in that it requires a restriction on the situations in which the predication holds. Although there is no restriction in (26), one must be found in the

⁷ For now, we will not take a stance on the copula in (25) as it is unimportant to our discussion of aspectual *be*.

discourse, for instance *when her mama calls her she be' lyin.* (26) implies that some type of situation that resulted in the subject lying has already occurred, and that if the situation arises again, it will have the same outcome. To better understand how this relates to the classification of copular predicates, we offer a discussion of genericity and habituality following Gerstner-Link and Krifka (1993), Heim (1982), and Green (2000).

Heim (1982) argues that generics have a tripartite structure, [Quantifier, Restriction, Nuclear scope]. Gerstner-Link and Krifka propose GEN to act as the quantifier in this tripartite structure in simple present tense SE sentences. The chief distinction between the generic and habitual readings of a simple present sentence, as put by Gerstner-Link and Krifka, is that the GEN operator in a generic quantifies over an individual in all situations, whereas the GEN operator in a habitual quantifies over an individual in a certain situation that could occur more than once. (3) is an example of a generic statement; GEN quantifies over John in any situation, whereas in (4), a habitual statement, GEN quantifies over John in a particular situation, after dinner. In the representations below, *s* denotes a situation.

(27) Generic: John smokes.

$GEN (x = \text{John} \wedge \text{in}(x, s) ; \text{smoke}(x,s))$

(28) Habitual: John smokes after dinner.

$GEN (x = \text{John} \wedge \text{after-dinner}(s) \wedge \text{in}(x,s); \text{smoke}(x,s))$

(Gerstner-Link and Krifka 1993; 975)

The GEN operator is weak because it allows for exceptions, that is, there can be situations for which John does not smoke. Furthermore, the generic structure does not entail a situation in which John has in fact smoked. Thus, it is possible to get a reading of (27) that means John would smoke, or does not object to smoking, not requiring that he has actually done so. We call this the 'no aversion' reading.

The distinction between genericity and habituality is important to our discussion of the aspectual *be* in AAVE. Green concludes that the interpretation of simple tense sentences with a generic reading can be extended to AAVE but that the aspectual *be* entails the existence of at least one situation in which the behavior described has occurred, aligning it with (28). The ‘no aversion’ reading is not possible with aspectual *be* sentences. In fact, Green argues that exceptions are not allowed in the reading given by aspectual *be* sentences either, further distinguishing them from simple present generics.

Green replaces the GEN quantifier in Heim’s structure with a HAB operator in aspectual *be* sentences to avoid the exceptions allowed by GEN and the ‘no aversion’ reading. Green also replaces the situation argument, *s*, in favor of eventualities, *e*. Although Green is not explicit about the nature of an eventuality, we understand that the an eventuality is a realized situation. The HAB quantifier must quantify over eventualities rather than situations, and in this way it does not allow the ‘no aversion’ reading. It necessarily entails an occurrence of the behavior described. Green further strengthens this operator by requiring that for every situation in which the behavior is predicted, it occurs. Consider Green’s example.

- (29) Bruce *be* cryin’ when the teacher call his mother.
HAB [call-his-mother(the teacher, *e*)] [cry (Bruce, *e*)]
(Green 2000; 11)

(29) is still of the structure [Quantifier, Restriction, Nuclear scope], as described by Heim. HAB quantifies over the restriction and the nuclear scope, the eventuality of the teacher calling Bruce’s mother and Bruce crying. (29) entails that there exists an instance of Bruce’s mother being called by the teacher and Bruce crying, and that if Bruce’s mother were again called by the teacher, Bruce would cry again. Green generalizes the function

of HAB even to sentences that do not explicitly state the restriction, as we saw in (26). To account for her claim that HAB sentences necessarily have a restriction, she uses the pragmatic variable, P, as introduced by Krifka and Gerstner (1987) to capture the eventuality described by the context but not explicit in the sentence.

- (30) Bruce be crying.
HAB_e [(P, e)] [cry (Bruce, e)]
(Green 2000; 11)

The pragmatic variable derives its meaning from the context of the utterance. Although the habit of crying in (30) does not seem bound to a particular event, the aspectual *be* forces us to look into the context for the restriction, which we represent with P above. (30) does not have a generic reading.

The necessity of predicates in aspectual-*be* sentences to be bound to events suggests that the aspectual *be* may function to some extent like *be_s*. Green suggests that such an event could be aligned with the event argument Kratzer describes as existing in the semantic type of SLPs but not in ILPs. We agree with this analysis of the aspectual *be* and propose that, in line with our theory, aspectual *be* constructions also have AspP, which forces its complements to be linked to an event and have a spatiotemporal argument.⁸

Aspectual *be* requires a variable in the nuclear scope and a restriction that can be bound, and accordingly, all of the predicates we have seen it compose with thus far have had a stage-level reading, which means that there is a spatiotemporal argument in their structure. As such, we predict that if the aspectual *be* selects a canonically individual-

⁸ We do not detail the syntactic structure of aspectual *be* as it is beyond the scope of this paper, although we postulate that it must introduce AspP into the syntax, which in turn will require the Event argument of the predicate.

level property, it will be coercively linked to an event argument. Green provides the following examples, which suggest that this coercion does take place.

- (31) Sue be having a lot of books.
(Sue usually/always has a lot of books with her.)
- (32) Sue be knowing that song.
(Sue usually/always shows that she knows that song.)

(adapted from Green 2000; 14)

The verbs *have* and *know* are typically considered individual-level because they are not generally linked to an event, and as we predict, when paired with aspectual *be* their meaning changes slightly. We direct the reader to Fernald (2000) for details of the coercion of ILPs to SLPs, who argues that the type structure of the predicates changes in certain coercive environments. We suggest that the aspectual *be* is one of those environments in AAVE; like AspP in *be_s*, AspP structure in the aspectual *be* forces the projection of a spatiotemporal argument in constructions like (31) and (32).

For the verb *know*, Green argues that our new understanding of the verb must be that the subject shows her knowledge of the song from time to time, not that she actually knew it one day and not the next. Fernald (2000) describes this type of change as Evidential Coercion, a form of coercion in which the behavior implied by the property is predicated of the subject. For instance, in the sentence, *she was so blond today*, the recipient might understand that the subject was acting like a blond person would, although the subject may not be blond. In (31), a person that has many books might be seen carrying them around, although without the aspectual *be*, *have* could not be used with that meaning. The crucial requirement of the aspectual *be* sentence is that the predicate can be linked to an event, so as long as for (32) we can imagine an event in

which the subject showed that she knew the song, quantification under the aspectual *be* is acceptable. In this case, the occasions on which the subject exhibited her knowledge, not the times that she actually had the knowledge, are bound by the quantifier implicit in the aspectual *be*. In this way, we are able to get a stage-level interpretation of the predicate. Notice that we would not be able to produce this reading without the aspectual *be*.

- (33) a. *Sue having a lot of books.
b. Sue has a lot of books.
- (34) a. *Sue knowing that song.
b. Sue knows that song.

The sentences (33a) and (34a) are not well formed in AAVE and suggest that the aspectual *be* requires an event argument of its predicate. We argue that the structure of the aspectual *be* coerces such an argument through the same means as *be_s*. We disagree with an analysis such as Becker's, that predicates come predefined as stage- or individual-level, and rather we propose that the aspectual *be* itself, as well as the copula, can force an event argument on the predicate. Note that we now have an analysis of the aspectual *be* under which it forces its complement to be stage-level, just as *be_s* does.

Becker argues that we observe the null copula only in the presence of AspP, and furthermore that a null copula never precedes an NP in CE because NPs cannot have an event argument. Therefore, NPs cannot be selected by *be_s*. Because NPs can follow null copulas in AAVE, Becker argues that her theory of copula absence in CE could not be applied to AAVE. We can use evidence from aspectual *be* clauses to assert that NPs in AAVE can occur with event arguments and thus be selected by verbs that require a spatiotemporal argument. Consider the following set of examples from Green (2000).

- (35) a. Bruce be running. VP
- b. Bruce be on the corner. PP

- c. Bruce be knowing the answers. VP
- d. Bruce be nice. AP
- e. Bruce be the choir director. NP

(Green 2000; 19)

Recall that all the sentences in (35) require a restriction to be found elsewhere in the discourse. The properties in (35a-d) are either canonically stage-level, or we have already discussed them and understand their coercion, e.g. *knowing*. The grammaticality of (35e) is surprising, but we turn to Green’s explanation to establish that it too is predictable. (35e) means that Bruce directs the choir given certain events. While Green attributes the stage-level nature of this reading perhaps too much to the transience of his post, we understand (35e) to mean that Bruce is only the choir director dependent on a certain event, perhaps the event of standing in front of the choir, or the event of the usual director not showing up for rehearsal. The property does not hold of him in general, and it is not sufficient to claim that (35e) means that Bruce has held the position of choir director multiple times throughout his life. The aspectual *be* forces *the choir director* to be linked to a set of events.

Whereas (35e) does not have an individual-level reading, Green claims that (36) has both an individual- and stage-level reading.

- (36) John the choir director.

(Green 2000; 19)

While we agree that (36) can have an individual-level reading, we find that Green’s explanation for (36)’s stage-level reading confuses permanence with an individual-level property. She claims that (36) could be stage-level in the case that John was only the choir director once; in fact the length of his stint as the director is not relevant to the individual or stage-level status of the predicate. Rather, it is only relevant whether the

predicate is linked to an event. If in (36), *choir director* were linked to an event as it was in (36e), then the predicate would be stage-level, but we cannot tell without more context which form of the copula is being used. The key element here is that the aspectual *be* must find an event argument in its complement.

If we extend Becker's theory of CE and claim that AAVE allows non-finite main clauses, we predict that the null copula will only occur in stage-level predicates and that if a canonically individual-level property is selected, it is coerced to take an event argument. As we have shown, even NPs can satisfy these requirements. Recall that Becker's analysis allowed copulas with AspP complements to delete. If we assume this behavior, it is not clear why the aspectual *be* would not also delete. Because the aspectual *be* also carries information about habituality, it may not be able to undergo deletion as the copula does in Child English stage-level predicates. We will not pursue this process further as it is out of the scope of this paper.

The effect of the syntactic category of the predicate was originally the pattern that led us to explore the ILP/SLP distinction as an explanation for AAVE copula absence, and now we have established that NPs, APs, and PPs can be forced to take an event argument, and as such can be selected by EvP. Therefore, if the null and overt AAVE copulas distinguish individual- and stage-level predicates, we should be able to categorize null-copula predicates as SLPs and overt-copula predicates as ILPs, and we should be able to explain the distribution of the null copula among the syntactic categories as Labov (1969) observed. We examine the distribution of the null-copula form with respect to properties of different syntactic categories and their readings as individual- or stage-level predicates.

The AAVE Null Copula and Individual- and Stage-level Predicates

Let us quickly recap our assumptions thus far. There are two entries for the copula in AAVE: be_s has AspP structure and be_i does not. The AspP structure selects EvP, which requires a spatiotemporal argument, such that if a property cannot be linked to an event it is rejected. Becker would argue that be_s never selects NPs because they cannot have event arguments, but we show that in AAVE, NPs can have event arguments, as seen in aspectual *be* constructions, which we showed has similar requirements to be_s . We expect to find that null-copula predicates are stage-level and overt ones individual-level. Such a result would match Cukor-Avila's findings that stativity relates to copula absence, Labov's findings that syntactic category correlates to copula absence, and perhaps Pustet's notion of the effect of time-stability.

We asked our informant for judgments on copular predicates containing a representative of each of the groups above, with the copula in full, contracted, and absent forms. Because Labov proposed that the copula might also vary with the preceding environment (pronoun or NP), we also varied this factor in the test sentences, but we observed no clear patterning on those lines. We suggest that because we limited our study to 3rd person forms, the category of the subject was subdued. Recall that earlier we recognized that the null copula was not allowed with 1st and 2nd person subjects, as well as 3rd person neuter subjects. A few examples are given below as a sample of the data provided to the informant without his markings for judgment (except for SE sentences, which we mark with *). The examples with un-emphasized *is* were included as a test for the informant, who always rejected them as SE.

- (37) a. Rover a dog. b. Rover's a dog. c. *Rover is a dog. d. Rover IS a dog.
 (38) a. Carl Puerto Rican. b. Carl's Puerto Rican. c. *Carl is Puerto Rican.
 d. Carl IS Puerto Rican.
 (39) a. He old. b. He's old. c. *He is old. d. He IS old.
 (40) a. That car too small. b. That car's too small. c. *That car is too small.
 d. That car IS too small.
 (41) a. The party at my house. b. The party's at my house. c. *The party is at
 my house. d. The party IS at my house.

Our informant found all of the forms (a,b) and (d) in all of the above examples to be well-formed, although he made distinctions between the emphasized, contracted, and null forms of the copula. Notice that all but (41) contain canonically individual-level properties. Given Becker's hypothesis about binding and our theory of the structure of the copula, we would predict that (37)-(41) be stage-level when introduced by a null copula because the presence of AspP would force them to link to an event. We asked our informant to tell us if the generally individual-level properties, such as *a dog*, *old*, and *small*, were stage-level in the null copula sentences. To elicit this judgment, we presented him with sentences including spatiotemporal modifiers, like *Carl Puerto Rican today* or *that car too small right now*, and sentences including adverbs of quantification, like *Whenever he old, he get tired real fast*. To our dismay, our informant did not find these sentences acceptable. He could not construct a context in which they were natural, and he detected no change in the way he understood the properties. Recall that coercion in aspectual *be* sentences was obvious – the same coercion did not occur here.

This information tells us that the presence of AspP does not determine the presence of the copula in AAVE. We had hypothesized that the null copula was really a deleted form of *be_s*, and that as such it would only appear in stage-level predicates. This is not the case. Although we still argue that there are two different forms of the copula, it

now seems that the null copula is not unique to stage-level predicates, and may equally be a form of *be_i*. The null copula in AAVE appears in individual- and stage-level predicates alike. Neither does it appear that the null copula is only appropriate in one of transient or permanent predicates. Recall that both *a dog* (individual-level) and *at my house* (stage-level) are introduced by null copulas in (37) and (41), the former permanent and the latter temporary.

This data suggest that we must look elsewhere to explain this variation, or we must agree that there is no semantic distinction at all and that the variation between overt and contracted copula is merely a phonological phenomenon. In this effort, we return to the data to see how, if at all, the absent-copula forms differ from their complementary overt-copula forms. In this section, we rely largely on our informant’s intuitions, and we recognize the scope of conclusions drawn from such a small study. While we recognize Green’s discussion of the inflectional forms of the copula in AAVE, the data we collected tells a slightly different story. Green claims that present tense copula morphology is the following, which we repeat for the reader’s convenience.

	Present copula	Emphatic affirmation	Negative
1 st singular	<i>'m</i>	AM	<i>'m not/ain't</i>
1 st plural, 2 nd singular/plural, 3 rd singular/plural	Null	IS	<i>Ain('t)/not</i>
3 rd singular neuter	<i>'s</i>	IS	<i>'s not/ain('t)</i>

Table 2

Recall that Green (2002) does not directly address the distribution of the contracted and null copulas even though the 3rd person singular and plural forms are universally accepted with the null or contracted copula. For our discussion, we focus on the environments that

accept the null or contracted copula without question – the 3rd person singular and plural forms.

When presented with sentences (42)-(49) in isolation, our consultant said that they were not natural used alone, but that he could build contexts in which they would be acceptable. He did not have this reaction to the contracted-copula complements of the sentences below. We mark this judgment, that the utterance requires a certain context, which we define further below, with %.

- (42) %He a dog.
- (43) %Darnell my neighbor.
- (44) %Zhane African.
- (45) %That car too small.
- (46) %Nelda fat.
- (47) %Brenda mad at you.
- (48) %Bowen Homes in Bankhead.
- (49) %Sean at school.

In the contexts that our informant built around (42)-(49), we noticed that the utterance was always used to address a doubt raised, correct a false claim, or ask for redress of a situation. The null copula forms all presupposed something contested, or contrary, in the discourse. Without that trigger, the null copula form is not accepted, and as such, is restricted to propositions contradicting an earlier proposition. For example, consider the two discourses below:

- (50) a. A: I like my new place.
b. It's cheaper than Bowen Homes, and
c. %Darnell my neighbor.
- (51) a. A: I like my new place.
b. It's cheaper than Bowen Homes.
c. B: Yeah but, Trey's your neighbor.
d. A: No, Darnell my neighbor.

(50c) is not appropriate in the discourse because there was no previous claim that Darnell is not in fact the subject's neighbor. In this case, (50c) presupposes a contradictory proposition in the discourse, a proposition such as (51c), but does not find it and fails. As such, (51d) is appropriate, because of its predecessor in the discourse.

The discourses that our informant built to make the forms in (45)-(49) natural all involved some sort of false claim and then a redress of that claim. For instance, (45) would follow naturally someone's suggestion that many friends pile into one rather small car, (46) from a suggestion to take Nelda on a date, (47) from a claim that Brenda was mad at someone else, and (49) from an accusation that Sean was skipping class. Although we will not make any more formal remarks about the role of the syntactic category of a property and its relation to the copula, we do suggest that it is more natural for some predicates to occur as the subject of debate than others. For instance, our informant had difficulty imagining a discourse in which a sentence like *she a girl* would be used. Perhaps if someone had suggested that a girl join an all-male football team, then it would be an appropriate response. But it seemed to our informant that certain very obvious or stable properties would not occur often with the null copula, and we suggest that the permanence of properties might correlate with certain syntactic categories.

We also want to stress that although addressing a contradictory claim is a manner of emphasis, the emphasized form of the copula (*IS*) is not the same as the null copula. Bender (2000) suggests that the null copula cannot be used to express emphasis and claims that the forms below are distinct⁹. Bender claims that these sentences should not

⁹ Bender's informants could not come to a clear decision on the acceptability of (53) as an equivalent to (52), but she maintains that the null copula cannot be used for emphasis.

be the same because phonologically empty elements cannot be stressed, and thus (53b) is not emphasized.

- (52) a: Don't ask Paul, he's no expert.
b: But he IS a expert.
- (53) a: Don't ask Paul, he's no expert.
b: But he a expert.

(Bender 2000; 84)

Our informant accepted both discourses, but he noted that without (53a), (53b) would not be accepted. (52b) is not subject to such a constraint; it does not presuppose a counterclaim in the discourse. (52b) is a slightly different form of emphasis, one that serves to address an earlier claim. We agree with Bender's point that a null copula cannot be the locus of emphasis, but we disagree with Green's claim that the null and contracted forms of the copula are equivalent. Rather, we argue that the null copula performs a distinct function in the discourse, not to be equated with the function of the emphasized or contracted copulas.

On a related note, our analysis supports a contrastive account of *ain't* and *not*, whereas Green aligns them. Both *ain't* and *not* can be used in AAVE to negate a proposition. Labov hypothesized that whereas *ain't* is a contracted form of the copula, *not* is not. Evidence for this claim comes from the distribution of *ain't*; *ain't* can appear environments such as tag questions where *not* cannot (Labov 1972), just as 's can appear in tag questions but the null copula cannot. In this study, we find further evidence that *not* does not have the same distribution as *ain't* or 's *not*. Consider (54) - (56). Although Green suggests that they are equivalent, our informant finds that there is a difference in the use of sentences (55) and (56).

- (54) He's not a dog.

- (55) He not a dog.
(56) He ain't a dog.

If someone accused *he* of being a dog (for now let us consider *dog* to be a derogatory term for another person), one could respond with (55) or (56). (55) indicates that the speaker disagrees and is correcting a previous claim. (56), rather, emphasizes the point that *he* is not a dog. In (55) we find the null copula, and in (56) an overt one. (54) is neutral, containing the contracted copula. While all of these sentences are grammatical, (55) would be inappropriate if there were no counterclaim in the discourse. (54) and (56) have no such presupposition, although (56) is a form of emphasis. Given the data seen thus far, we conclude that the null copula presupposes a contrary proposition, and *not* is a naturally analogous form.

In the small range of sentences and discourses we have examined, we have concluded that there is a pragmatic constraint on the use of the null copula in the 3rd person, and that the contracted copula is the unmarked form. This suggestion is further evidenced by the fact that the null copula is prohibited in certain environments, such as tag questions. We have not suggested how the pragmatic use of the null copula could account for those restrictions; in fact, we have thus far considered only the environments in which both forms of the copula were explicitly allowed. Due to the scope of this study, we do not attempt to use pragmatics to explain the restrictions on null copula use. Instead, we propose that this pragmatic constraint be paired with a syntactic account of the null copula in AAVE, like the silent verb account Bender (2000).

In one of Bender's (2000) syntactic analyses of the AAVE copula, which she calls a silent verb analysis, she argues that the null copula is an inflectional form of the copula, equivalent to *is* and *are*. For instance, the silent copula agrees with the 2nd and 3rd person

forms, but not with the 1st person. Bender identifies a set of environments that prohibit the null form and postulates a set of constraints to account for them. The environments are summed in the Figure 11 below, and they align essentially with Labov's (1969) findings as well.

-
- a. nonfinite contexts
 - b. imperatives
 - c. ellipsis
 - d. emphasis
 - e. past tense
 - f. inversion
 - g. complement extraction
-

Figure 11

(Bender 2000; 83)

We have not discussed these environments at length but rather have focused on environments in which the null and contracted copula can both appear so that we could judge the difference in the meaning and use of such sentences. It is not immediately clear that any of these constraints are related to the pragmatic one discussed above, but it is possible that such an argument could be made. Labov (1969) suggests that the forced appearance of the copula in some of these environments may have to do with tense information, whereas Bender does not provide much insight on the similarities in the restricted environments.

This account of copula absence in Bender is attractive because the syntactic constraints on the silent copula are finite and predictable. We forward the reader to her full account to see that it correctly predicts the syntactic environments in which the null copula can occur. Although it incorporates restrictions that Green's simplified account of the inflectional forms of the copula does not, it still does not capture the contrastive meaning that the null copula carries. Even if the null copula could syntactically appear in

a sentence, the contracted copula can still be chosen, given the pragmatics of the sentence. Still, interpreting the null copula not as a separate verb, but as a form of one of the underlying copulas, lends itself well to the observations we made earlier – the underlying copula provides the individual- or stage-level reading of the predicate, and the null form just links the proposition to the discourse. Thus, we argue, building on Bender’s syntactic analysis, that the null copula is an inflectional form of both copulas, *be_s* and *be_i*, and that one of the restrictions on it is pragmatic – it presupposes a contrary proposition in the discourse.

Conclusion

In this thesis we have come a far way from Labov’s initial observation that the null copula appeared with different likelihood preceding different syntactic categories. This discrepancy led us to consider the individual- and stage-level predicate distinction because that distinction may govern copular form in languages such as Spanish and because time-stability and stativity were related to both the predicate distinction and to copula presence (Becker 2004; Pustet 2003; Cukor-Avila 1999). During our investigation, we proposed that there are two forms of the copula in AAVE although they are homophonous, and that the individual- and stage-level predicate distinction is also made in AAVE by the aspectual *be*. This result was important in showing that properties can be coerced into projecting a spatiotemporal argument regardless of their syntactic category, allowing us to assert that this coercion might also happen with NPs in AAVE copular predicates. Despite showing that certain AAVE environments do impose individual- or stage-level reading on the properties being predicated of the subject, and that these

properties may be of any syntactic class, we found that the null copula is not unique to stage-level predicates in AAVE. Given this finding, Becker's theory that the null copula can delete as a result of the binding of AspP, which is only found in stage-level predicates, we had to look elsewhere for the constraint on the null copula in AAVE.

We found that the null copula is governed by a pragmatic constraint on the incorporation of the proposition into a discourse. We argue that the null form of the copula presupposes another proposition, one of contrary nature, in the discourse. Although we were not able to build a comprehensive theory of how this constraint can be modeled, we suggest that this pragmatic constraint might be incorporated into a syntactic theory such as the silent verb analysis given by Bender (2000). We also recognize that there might be potential to represent this constraint through a pragmatic variable, like the method by which the aspectual *be* can find a restriction for a quantifier in the discourse, or to account for the syntactic restrictions on the null copula through an extension of the pragmatic restrictions on it.

The AAVE null copula is not merely an extension of contraction; it has distinct meaning in the discourse and constraints on its use. Incorporating this pragmatic constraint into Bender's theory allows us to predict its distribution although we have not analyzed the other syntactic environments in which the null copula is restricted. Further work could examine questions, imperatives, and other tenses to see how much of the distribution the pragmatic constraint could account for, as well as the null form of the auxiliary *be*. This theory still does not explain the initial observation that the null copula occurs with greater frequency with certain predicates. It could be the case that certain predicates are more likely to cause debate or require contradiction in a discourse. For

instance, our informant claims that a form like *she a girl* is very difficult to imagine, if only because we do not generally debate gender. Further study might include analysis of a predicate's salience in this discourse environment, but any study should be careful to recall the syntactic constraints on the copula and identify only environments in which the null copula has clear contrastive meaning. We also recognize the limited scope of our study, which only involved one native speaker. Although we were able to recognize a pattern in our speaker's use of the null copula, analysis of a group of young speakers would be necessary to generalize this claim.

References

- Bailey, G. and N. Maynor. 1987. Decreolization? *Language in Society* 16.449-474.
- Becker, Misha. 2004. The development of the copula in child English: the lightness of *be*. *University of Pennsylvania IRCS Technical Report Series* 00.05.
- Bender, Emily. 2000. Syntactic variation and linguistic competence: the case of AAVE copula absence. Stanford University. (unpublished dissertation).
- Carlson, G. 1977. Reference to kinds in English. University of Massachusetts Amherst. (dissertation: UMass Amherst).
- Carlson, Gregory and Francis Pelletier. 1995. *The Generic Book*. London: University of Chicago Press.
- Cedergren, H. and D. Sankoff. 1974. Variable rules: Performance as a statistical reflection of competence. *Language* 50.333-355.
- Chierchia, G. 1984. Topics in the syntax and semantics of infinitives and gerunds. University of Massachusetts Amherst. Ph.D Dissertation.
- Cukor-Avila, Patricia. 1999. Stativity and copula absence in AAVE: Grammatical constraints at the subcategorical level. *Journal of English Linguistics* 27.341.
- Davidson, D. 1967. The logical form of action sentences. *Essays on actions and events*. Oxford, Oxford University Press: 105-148.
- Debose, Charles. 1994. A note on *ain't* vs. *didn't* negation in African American Vernacular. *Journal of Pidgin and Creole Languages* 9:127-30.
- Doron, E. 1983. Verbless predicates in Hebrew. University of Texas at Austin. Ph.D. dissertation.
- Dowty, D. 1979. *Word meaning and Montague Grammar*. D. Reidel
- Enç, M. 1991. The semantics of specificity. *Linguistic Inquiry* 22.1-26.
- Fasold, R. 1972. Tense Marking in Black English. Center for Applied Linguistics, Arlington.
- Felser, C. 1999. Verbal complement clauses: A minimalist study of direct perception constructions. Philadelphia, John Benjamins Publishing Co.

- Fernald, Theodore. 2000. *Predicates and Temporal Arguments*. New York: Oxford University Press.
- Ferguson, Charles and Thom Huebner. 1996. Absence of copula and the notion of simplicity: a study of normal speech, baby talk, foreigner talk, and pidgins. *Sociolinguistic Perspectives: Papers on Language in Society, 1959-1994*. 115-125
- Fickett, Joan. 1975. Ain't, not, and don't in Black English. *Perspectives on Black English*. Ed. by Joshua A. Fishman. The Netherlands: Mouton & Co. 86-90
- Gerstner-Link, C. and M. Krifka. 1993. Genericity. *Encoding of Semantic Aspects of Meaning*. Ed. by J. Jacobs, A. von Stechow, W. Sternefeld, and T. Vennemann. An International Handbook of Contemporary Research. De Gruyter, New York. 1.966-978.
- Green, Lisa. 2000. Aspectual be-type constructions and coercion in African American English. *Natural Language Semantics* 8.1–25.
- Green, Lisa. 2002. *African American English: A linguistic introduction*. Cambridge: Cambridge University Press.
- Green, Lisa. 2004. Research on African American English Since 1998: Origins, Description, Theory, and Practice. *Journal of English Linguistics* 32.210.
- Givón, Talmy. 1970. Notes on the Semantic Structure of English Adjectives. *Language* 46.816-37.
- Givón, Talmy. 1984. *Syntax: A Functional-Typological Introduction*. Philadelphia, PA: John Benjamins.
- Heycock, C. 1995. The internal structure of small clauses: New evidence from inversion. Proceedings of NELS 25, Amherst, MA, GLSA.
- Holm, John. Variability of the Copula in Black English and the Creole Kin. *American Speech*. 59.4.291-309.
- Kratzer, A. 1989. Stage and individual level predicates. Papers on Quantification. NSF Grant Report, Linguistics Department, University of Massachusetts, Amherst.
- Kratzer, A. 1995. Stage-level and individual-level predicates. *The Generic Book*. Ed. by G. Carlson and F. Pelletier. Chicago, University of Chicago Press: 125-175.
- Krifka, M. and C. Gerstner. 1987. An Outline of Genericity. Seminar für natürlich-sprachliche Systeme, Universität Tübingen. SNS-Bericht 87.25.1–34,
- Labov, William. 1969. Contraction, Deletion, and Inherent Variability of the English Copula. *Language* 45.715-62.

- Labov, William. 1972. *Language in the inner city*. Philadelphia: University of Pennsylvania Press.
- Lakoff, George. 1966. Stative Adjectives and Verbs in English. Unpublished manuscript.
- Lakoff, George. 1970. *Irregularity in Syntax*. New York: Holt, Rinehart, and Winston.
- Maienborn, Claudia. Review of Regina Pustet: *Copulas. Universals in the categorization of the lexicon*. (to appear in *Studies of Language*)
- Pustet, Regina. 2003. Copulas: Universals in the Categorization of the Lexicon. *Oxford Studies in Typology and Linguistic Theory* 14.262.
- Ramchand, G. C. 1996. Two Subject Positions in Scottish Gaelic: The Syntax-Semantics Interface. *Natural Language Semantics* 4.165–191
- Rickford, J.R. 1998. The Origins of African American Vernacular English: Evidence from Copula Absence. In *African-American English: Structure, History and Use*, edited by Salikoko S. Mufwene, John R. Rickford, Guy Bailey, and John Baugh. New York: Routledge. 154-200.
- Rickford, J. R. 1999. *African American Vernacular English: Features, evolution, educational implications*. Malden, MA, Blackwell.
- Sera, M. 1992. To be or to be. *Journal of Memory and Language* 31.408-427.
- Stassen, Leon. 2003. *Intransitive Predication*. 212-215
- Walker, James A. 2000. Rephrasing the Copula: Contraction and Zero in Early African American English. *The English History of African American English*. Ed. by Shana Poplack. Malden, MA: Blackwell. 35-72.
- Weldon, Tracey. 2003. Copula Variability in Gullah. *Language Variation and Change* 12.37-72.